

# 359 PETERBILT FENDER SHIELDS

FOR P/N 08049L, 08050 & 08149L

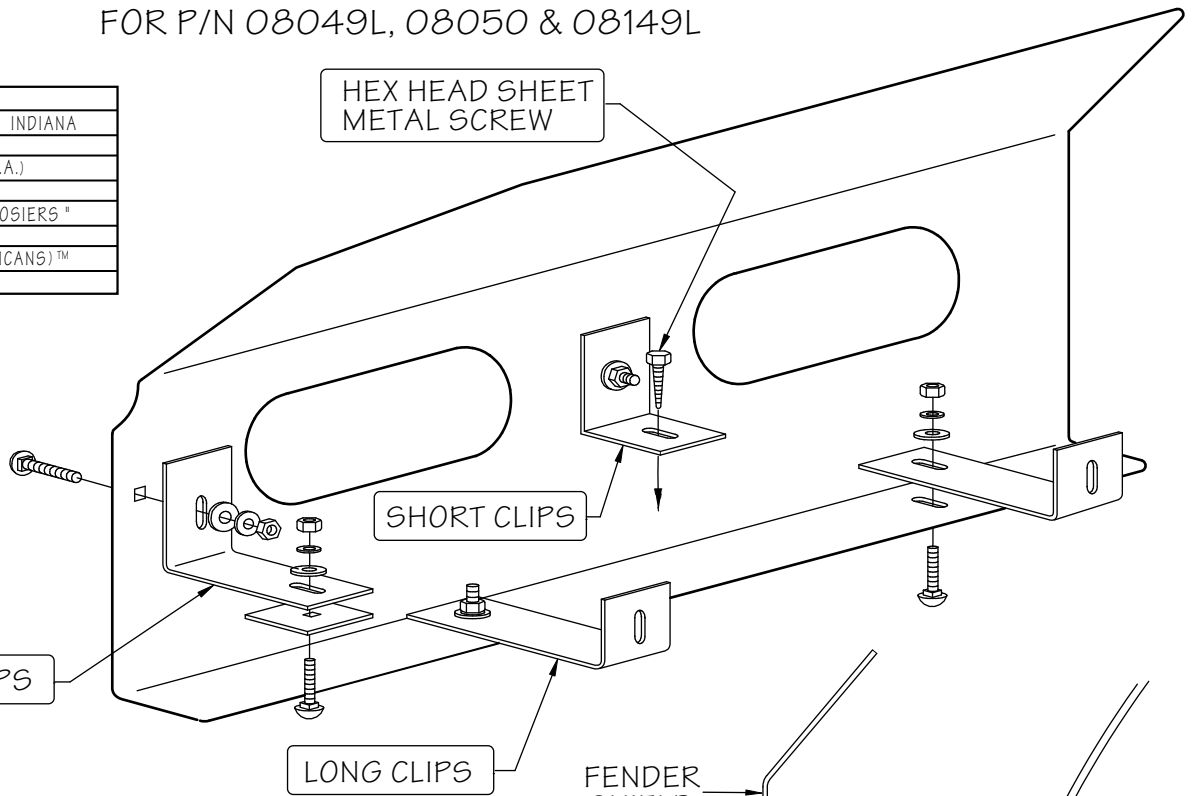
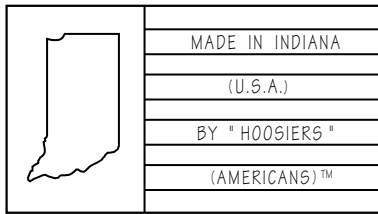

## INSTRUCTIONS

1. MOUNT THE TWO SHORT MOUNTING CLIPS TO THE MIDDLE OF EACH FENDER SHIELD WITH 1/2" LONG CARRIAGE BOLTS.
2. MOUNT THE TWO MID-SIZE CLIPS TO THE SIDE OF EACH FENDER SHIELD (BY ANGLED DOWN CUTS) WITH 1/2" LONG CARRIAGE BOLTS. **NOTE!** THE LONG PART OF THE CLIP WILL SET ON TOP OF THE STEP WITH THE 2" SQUARE PLATES UNDER THE STEP.
3. MOUNT TWO LONG CLIPS TO THE BOTTOM OF EACH FENDER SHIELD AND LEAVE "FINGER TIGHT".
4. PLACE EACH FENDER SHIELD IN THE DESIRED POSITION ON TOP OF THE STEP AND MARK THE HOLE AT THE SHORT END OF STEP TO RECEIVE THE HEX HEAD SHEET METAL SCREW.
5. REMOVE THE FENDER SHIELDS AND DRILL THE HOLE TO RECEIVE THE SHEET METAL SCREW.
6. MOUNT THE FENDER SHIELD ON TOP OF THE STEP WITH THE SHEET METAL SCREW FIRST. THEN PLACE THE LONG BOLT UP FROM THE BOTTOM, THRU THE 2" SQUARE PLATE, STEP AND THEN THE CLIP AS SHOWN IN THE SIDE VIEW.
7. MARK THE FOUR HOLES UNDER THE FRONT OF THE FENDER. REMOVE THE **CLIPS** AND DRILL THESE HOLES.
8. REMOUNT THE CLIPS AND TIGHTEN ALL BOLTS.
9. IF YOU HAVE PURCHASED A MODEL WITH LIGHTS, YOU ARE READY TO INSTALL AND WIRE THE LIGHTS. THE LIGHTS MAY BE WIRED FOR MARKER AND/OR TURN SIGNALS.

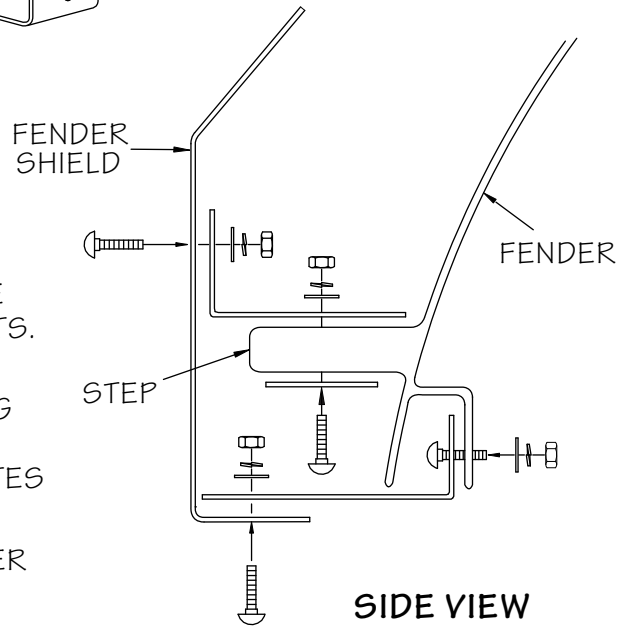

BY

