

379 PETERBILT FENDER SHIELDS

	MADE IN INDIANA
	(U.S.A.)
	BY "HOOSIERS"
	(AMERICANS)™

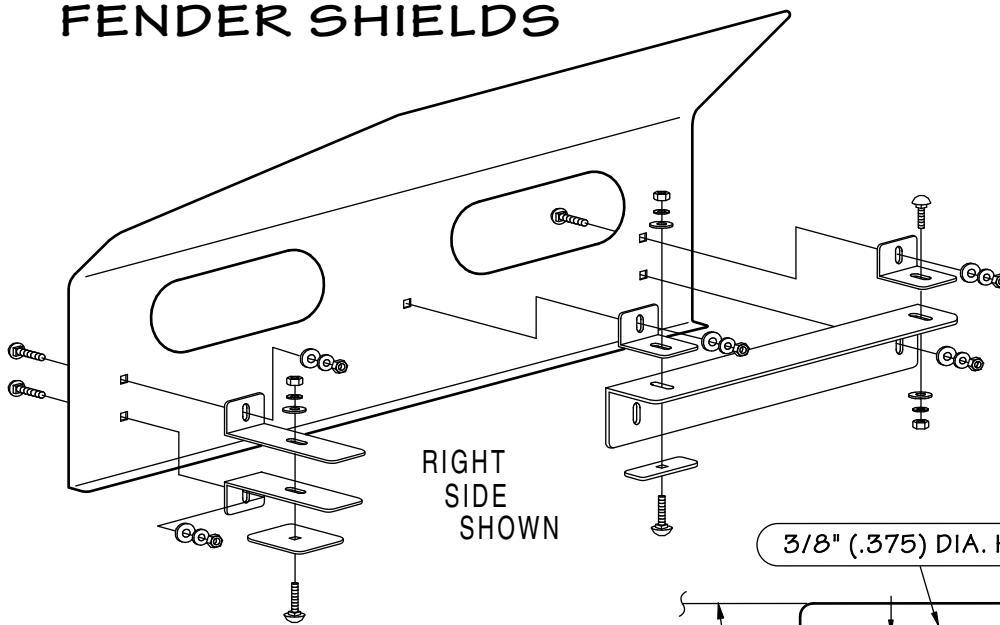

RIGHT
SIDE
SHOWN

ALUMINUM
STEP

RADIATOR
TRIM

3/8" (.375) DIA. HOLE

FENDER

7/8"

10 7/8"

INSTRUCTIONS

1. LEAVE ALL BOLTS "FINGER-TIGHT" UNTIL THE UNITS ARE COMPLETELY INSTALLED AS THEY WILL HAVE TO BE ADJUSTED FOR PROPER ALIGNMENT.
2. INSTALL TWO 3-3/4" LONG ANGLE SHAPED BRACES ON THE **SLOPED** END OF THE FENDER SHIELD USING TWO SMALL CARRIAGE BOLTS, NUTS, AND LOCKWASHERS.
3. INSTALL ONE LONG AND TWO SHORT ANGLE BRACES **OPPOSITE** THE SLOPED END USING THREE SMALL AND ONE LARGER CARRIAGE BOLTS, NUTS, AND LOCKWASHERS. **NOTE:** THE LONG ANGLE BRACE REQUIRES ONE BOLT ONLY AND MOUNTS WITH THE TWO **LARGER** SLOTS FACING UP.
4. LOCATE AND DRILL THE TWO 3/8" (.375 DIA.) HOLES IN THE ALUMINUM STEP AS SHOWN IN THE "HOLE LOCATION ILLUSTRATION". (ONE HOLE IN EACH STEP - 7/8" FROM THE FRONT OF THE STEP).
5. PLACE THE ASSEMBLY ON TOP OF THE STEP. INSERT ONE LONG CARRIAGE BOLT THROUGH THE SMALL PLATE WITH A SQUARE HOLE. INSTALL THIS UNIT UP FROM THE BOTTOM (HOLLOW PART) OF THE STEP AND ON THROUGH THE DRILLED HOLE AND BOTH ANGLE BRACES. PLACE A NUT, WASHER, AND LOCKWASHER ON THE BOLT. (SEE "SIDE VIEW")
6. INSERT ONE LONG CARRIAGE BOLT THROUGH THE LARGE PLATE WITH A SQUARE HOLE. INSTALL THIS UNIT FROM UNDER THE **OPEN** PART OF STEP AND THROUGH BOTH ANGLE BRACES. PLACE A NUT, WASHER, AND LOCKWASHER ON THE BOLT.
7. PROPERLY ALIGN THE FENDER SHIELDS AND TIGHTEN ALL BOLTS. **NOTE!** IT IS A GOOD IDEA TO APPLY A SMALL AMOUNT OF "LOCTITE" TO THESE BOLTS TO PREVENT THEM FROM VIBRATING LOOSE DURING NORMAL TRUCK OPERATIONS.
8. IF YOU HAVE PURCHASED ONE OF THE LIGHTED MODELS, YOU ARE NOW READY TO INSTALL THE LIGHTS AND CONNECT THE WIRING.
9. USE WINDEX AND A SOFT COTTON CLOTH TO CLEAN THE FENDER SHIELDS AFTER THE INSTALLATION IS COMPLETED. NEVER USE AN ABRASIVE COMPOUND TO CLEAN THE STAINLESS AS IT WILL DAMAGE THE FINISH.

HOLE LOCATION ILLUSTRATION

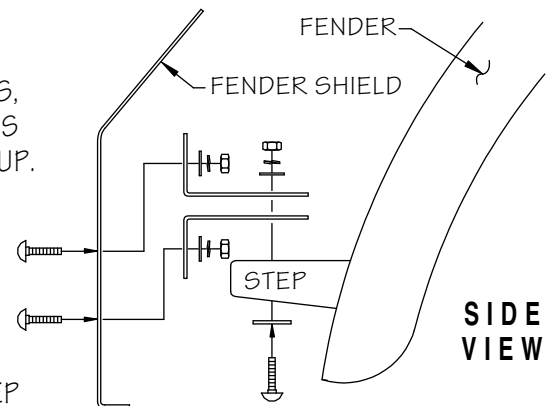

SIDE
VIEW



BY

