

FREIGHTLINER MID FAIRING TRIM CHANNELS

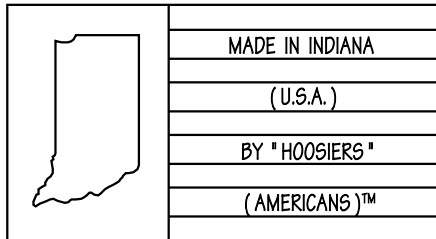
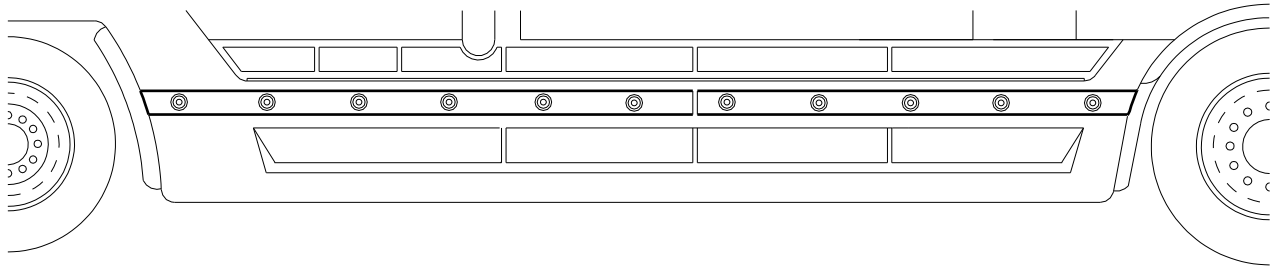
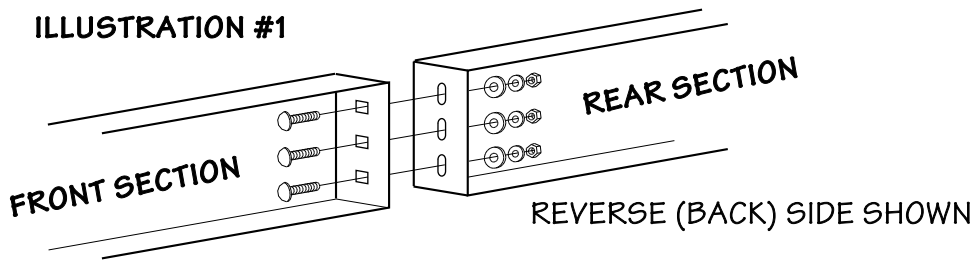

ILLUSTRATION #1



INSTRUCTIONS

1. LAY THE PANELS OUT AND DETERMINE THE FRONT AND REAR PANELS. NOTE THAT THE FRONT PANELS ALWAYS HAVE THE SQUARE HOLES WHERE THE TWO SECTIONS JOIN. SEE ILLUSTRATION #1
2. MEASURE AND CAREFULLY DETERMINE THE CENTER OF THE MOUNTING AREA BOTH AT THE FRONT AND THE REAR OF TRUCK. SNAP TWO CHALK LINES THE ENTIRE LENGTH OF THE TRUCK ONE INCH ABOVE AND ONE INCH BELOW THE CENTER OF THE MOUNTING AREA. **NOTE!** THIS WILL SERVE TO LOCATE THE MOUNTING SCREWS.
3. PLACE THE FIRST PANEL INTO THE PROPER MOUNTING POSITION AND DRILL THE 1/8" HOLES ON THE CHALK LINES AND THRU THE FIRST LIGHT HOLE. (THESE HOLES NEED ONLY TO BE "EYEBALL" CLOSE AS THERE IS PLENTY OF ROOM FOR LATER ADJUSTMENT)
4. PLACE ONE OF THE MOUNTING PLATES THRU THE LIGHT HOLE, ROTATE THE PLATE UNTIL VERTICAL, LINE THE HOLES UP WITH THE DRILLED HOLES AND MOUNT WITH SHEET METAL SCREWS. SEE ILLUSTRATIONS #2 & #3
5. REPEAT THIS STEP AT THE OTHER END OF THE PANEL AND AT EVERY HOLE IN THE PANEL.
6. REPEAT STEPS #3, #4 & #5 TO MOUNT THE REMAINING PANELS.
7. YOU ARE NOW READY TO INSTALL AND WIRE THE LIGHTS.

ILLUSTRATION #2

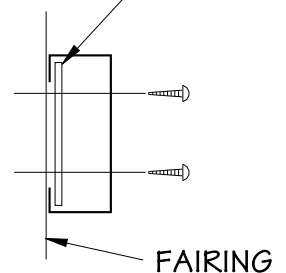
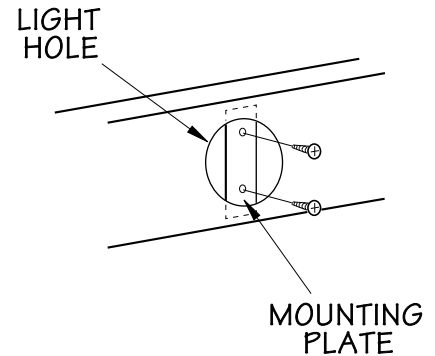

ILLUSTRATION #3



BY

