

# FREIGHTLINER "CLASSIC XL" FENDER SHIELDS

|   |                 |
|---|-----------------|
|  | MADE IN INDIANA |
|   | (U.S.A.)        |
|   | BY "HOOSIERS"   |
|   | (AMERICANS)™    |

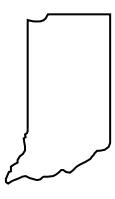
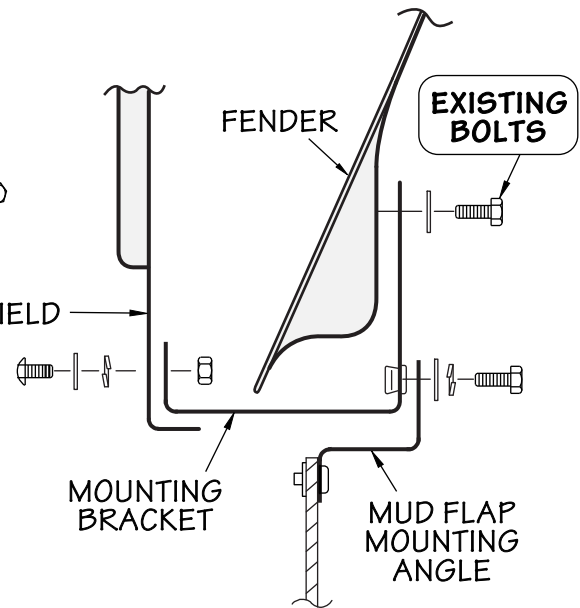
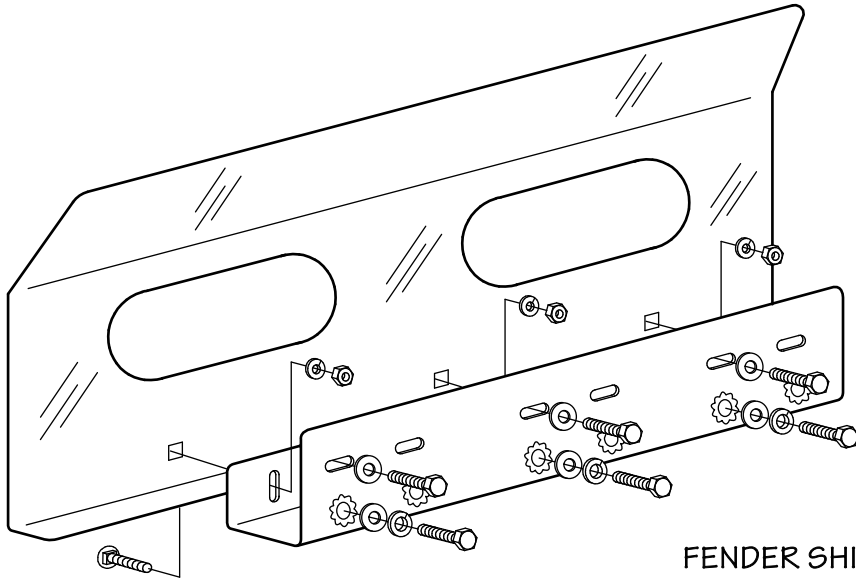

SIDE VIEW

## INSTRUCTIONS

1. REMOVE THE MUD FLAP MOUNTING ANGLE FROM BEHIND THE FENDER AND STORE THE BOLTS IN A CONTAINER AS WE WILL RE-USE THEM TO MOUNT THE FENDER SHIELDS.
2. ATTACH THE MOUNTING BRACKETS TO THE REAR OF THE FENDER SHIELDS USING THE CARRIAGE BOLTS FURNISHED IN THE KIT. MAKE SURE THE BRACKETS ARE RESTING AGAINST THE BOTTOM AND TIGHTEN. **NOTE!** THE BIAS-CUT ENDS AT THE TOP OF THE FENDER SHIELDS MOUNT **NEXT** TO THE GRILL.
3. MOUNT THE ASSEMBLY IN PLACE UTILIZING THE EXISTING BOLTS YOU HAVE PREVIOUSLY REMOVED. (SEE SIDE VIEW)
4. ADJUST THIS UNIT FOR SIDE TO SIDE ALIGNMENT AND TIGHTEN. THIS IS ALSO A GOOD TIME TO CHECK THE UNIT FOR THE PROPER HEIGHT AND MAKE ANY NECESSARY ADJUSTMENTS.
5. INSTALL THE MUD FLAP MOUNTING ANGLE AGAINST THE NEW FENDER SHIELD BRACKET UTILIZING THE NEW BOLTS SUPPLIED IN THIS KIT AND TIGHTEN.
6. IF YOU HAVE PURCHASED A MODEL WITH LIGHTS, YOU ARE NOW READY TO INSTALL AND WIRE THE LIGHTS.



BY

