

KENWORTH AIR CLEANER SHIELDS

P/N 28085, 28086L, 28185, 28186L,
28385 & 28386L

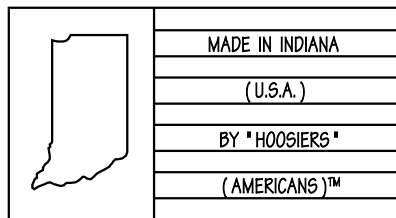

by

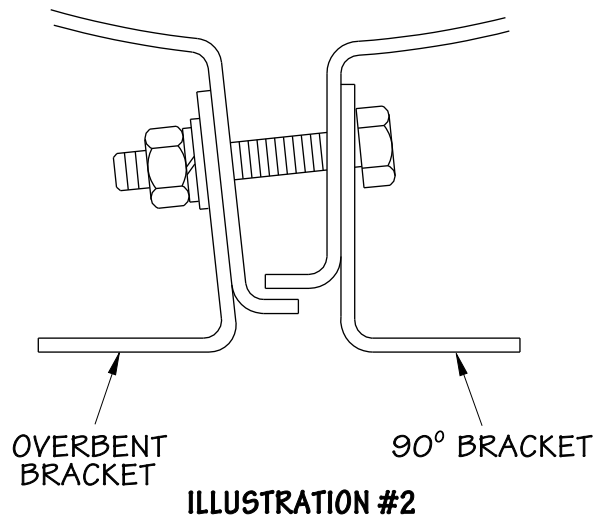
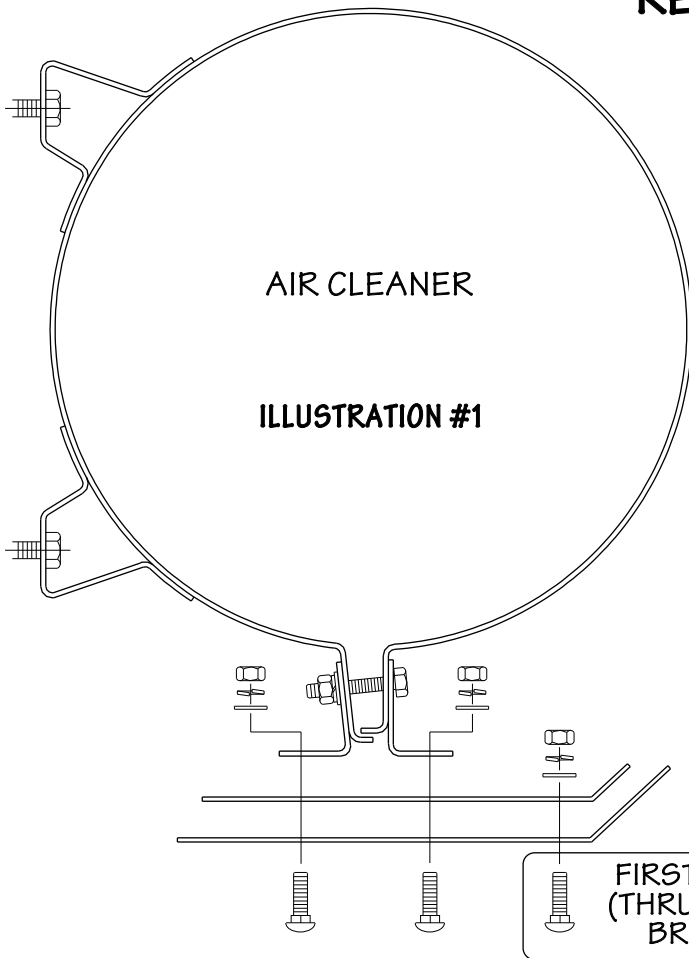

INSTRUCTIONS

1. BOLT THE ANGLE BRACKETS ONTO THE AIR CLEANER BANDS UTILIZING THE LONGER HEX BOLTS FURNISHED IN THE KIT. TAKE CARE TO GET THE BRACKETS IN THE PROPER LOCATION (SEE ILLUSTRATION #2)
2. INSERT ONE CARRIAGE BOLT THRU THE AIR CLEANER SHIELD AND THE SUPPORT BRACE AND TIGHTEN. **NOTE!** THIS IS THE BOLT NEAREST THE BEND IN THE AIR CLEANER SHIELD (SEE FIRST BOLT IN ILLUSTRATION #1)
3. PLACE THE THREE PIECE ASSEMBLY INTO POSITION AND INSTALL THE CARRIAGE BOLTS THRU THIS ASSEMBLY AND THE ANGLE BRACKETS TO A FINGERTIGHT CONDITION.
4. CHECK FOR PROPER ALIGNMENT AND TIGHTEN ALL BOLTS.
5. IF YOU HAVE PURCHASED A MODEL WITH LIGHTS, YOU ARE NOW READY TO INSTALL AND WIRE THE LIGHTS.