

KENWORTH W900 FENDER SHIELDS

P/N 28050, 28056L, 28150 & 28156L

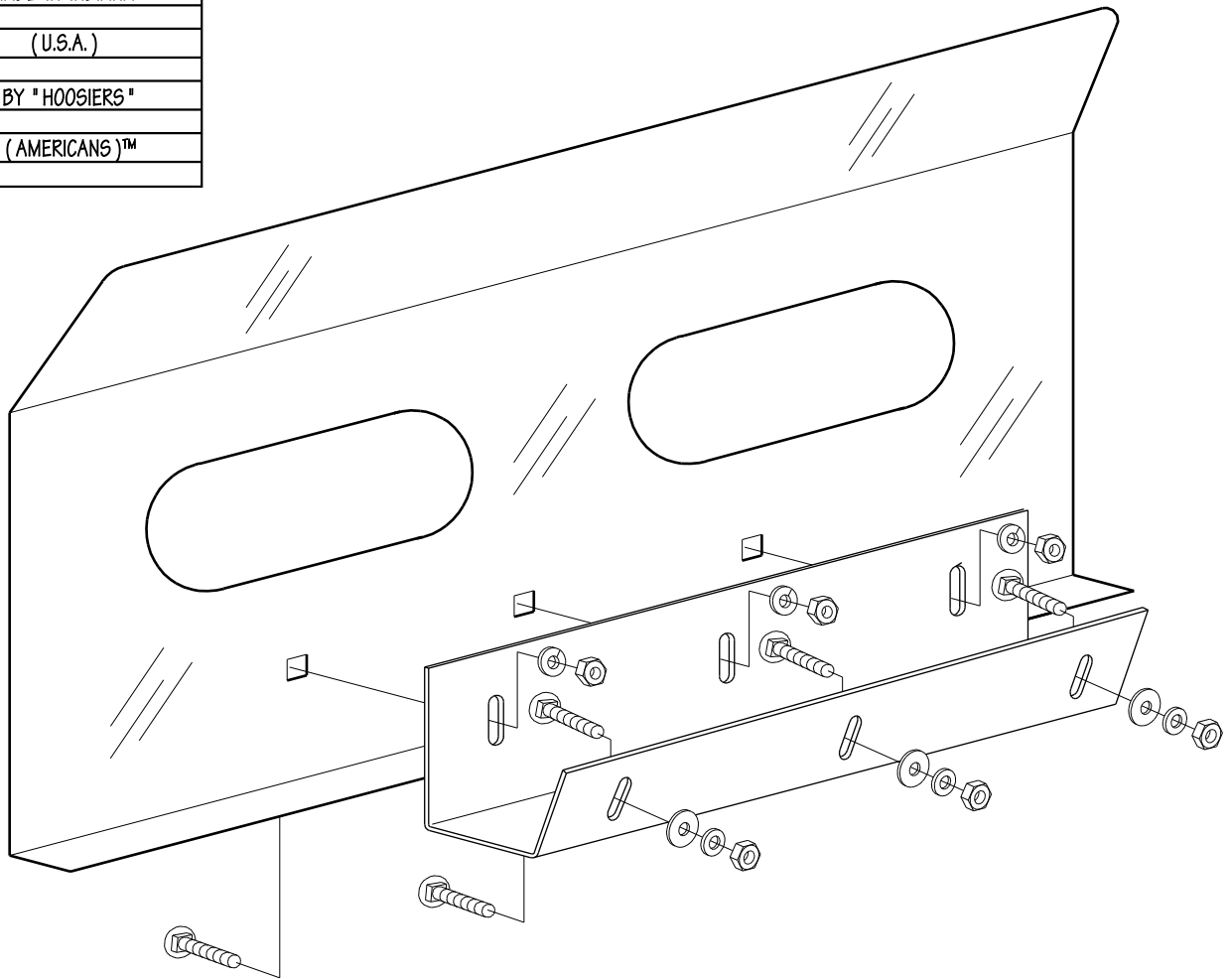
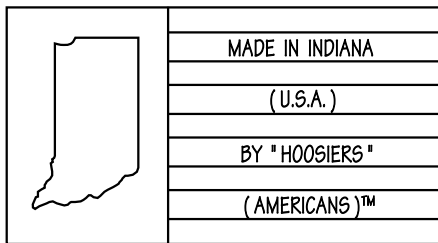

INSTRUCTIONS

1. MOUNT THE LONG BRACKET IN BACK OF THE FENDER SHIELD TO A "FINGER TIGHT" CONDITION.
2. CAREFULLY POSITION THIS ASSEMBLY TO THE DESIRED LOCATION AND MARK THE THREE HOLES TO BE DRILLED IN THE FENDER.
(**NOTE!** THE SIDE TO SIDE LOCATION OF THESE HOLES ARE IMPORTANT AND THE VERTICAL SLOTS ALLOW FOR UP AND DOWN ADJUSTMENT AFTER INSTALLATION.)
3. DRILL THE THREE 5/16" DIAMETER HOLES IN THE FENDER.
4. MOUNT THE ASSEMBLY IN PLACE, CHECK FOR PROPER ALIGNMENT, ADJUST AND TIGHTEN ALL BOLTS.
5. IF YOU HAVE PURCHASED A MODEL WITH LIGHTS, YOU ARE NOW READY TO INSTALL AND WIRE THE LIGHTS.

COPYRIGHT © 2007
RigSkirts LLC.

11/5/2007
28150INS



BY

