

HALF FENDER ASSEMBLY INSTRUCTIONS (FENDERS WITHOUT MOUNTS OR MOUNTING HOLES)

	MADE IN INDIANA
	(U.S.A.)
	BY "HOOSIERS"
	(AMERICANS)™

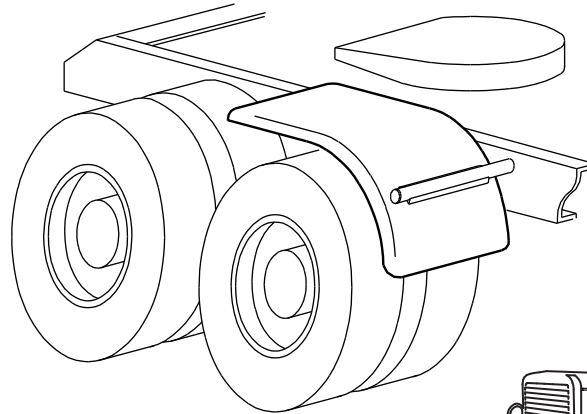

BY

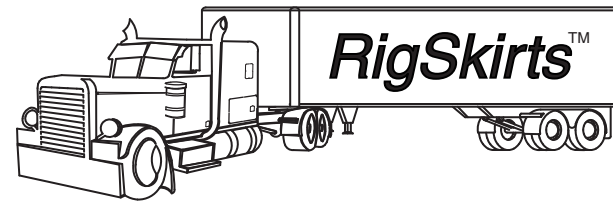

LIMITED WARRANTY

WHAT IS COVERED UNDER MY LIMITED WARRANTY?

THIS WARRANTY COVERS ALL DEFECTS IN MATERIALS AND/OR WORKMANSHIP IN YOUR **RigSkirts™** PRODUCTS PROVIDED THEY ARE INSTALLED AS OUTLINED IN THE ASSEMBLY INSTRUCTIONS.

HOW LONG IS THE PERIOD OF COVERAGE?

THE WARRANTY REMAINS IN FORCE FOR 90 DAYS FROM THE DATE YOU PURCHASE YOUR **RigSkirts™** PRODUCTS.

WHO DETERMINES LIABILITY UNDER THIS WARRANTY?

WE WILL INSPECT THE PARTS AND DETERMINE IF THEY QUALIFY FOR COVERAGE ACCORDING TO THE TERMS AND LIMITATIONS OF THIS WARRANTY.

WHAT IS NOT COVERED IN THIS WARRANTY?

LOSS OR DAMAGE DUE TO IMPROPER MOUNTING, ROAD HAZARD, FIRE, THEFT, COLLISION, NEGLIGENCE OR MISTREATMENT. LIABILITY IN ALL CASES IS LIMITED TO THE PURCHASE PRICE PAID FOR THE PRODUCT.

ONE PIECE TANDEM FENDERS ARE NOT COVERED UNDER THIS OR ANY OTHER LIMITED WARRANTY.

THE COST FOR INSTALLATION AND/OR REMOVAL OF ANY **RigSkirts™** PRODUCT IS NOT COVERED.

DAMAGE RESULTING FROM THE INSTALLATION AND/OR USE OF ANY ELECTRICAL COMPONENTS SHALL BE THE RESPONSIBILITY OF THE PURCHASER.

ALL LIGHTS ARE COVERED BY THEIR RESPECTIVE MANUFACTURERS WARRANTY.

IF THE PARTS ARE FOUND TO BE DEFECTIVE, WHAT DO YOU DO?

WE WILL REPAIR OR REPLACE THE PARTS FOUND TO BE DEFECTIVE AND SHIP THEM BACK TO YOU FREIGHT PREPAID.

WHAT MUST I HAVE TO GET MY DEFECTIVE PARTS REPLACED?

A COPY OF THE ORIGINAL INVOICE SHOWING THE "PROOF OF PURCHASE" DATE.

HOW DO I GET DEFECTIVE PARTS REPAIRED OR REPLACED?

SEND THE PARTS IN THE ORIGINAL CARTON ALONG WITH PROOF OF PURCHASE DATE TO OUR FACTORY PREPAID FOR PROMPT SERVICE. FOR ADDITIONAL INSTRUCTIONS, SEE "POLICES & GENERAL INFORMATION" PAGE OF OUR CATALOG.

WHAT ARE MY RIGHTS UNDER STATE LAW?

THIS WARRANTY GIVES YOU SPECIFIC LEGAL RIGHTS, AND YOU MAY ALSO HAVE OTHER RIGHTS WHICH VARY FROM STATE TO STATE.

HALF FENDER MOUNTING INSTRUCTIONS (FENDERS WITHOUT MOUNTS OR MOUNTING HOLES)

INSTRUCTIONS

RigSkirts™ OFFERS A WIDE RANGE OF FENDER MOUNTING KITS.

ASK YOUR DEALER FOR DETAILS

1. SEE MOUNT LOCATING DETAILS BELOW TO ASSIST IN LOCATING THE FRONT MOUNTS. FRONT MOUNTS LOCATED OUTSIDE THE MIN-MAX RANGE AND LACK OF THE PROPER DISTANCE BETWEEN THE FRONT AND REAR MOUNTS VOIDS THE WARRANTY AND WILL INTRODUCE UNNECESSARY FENDER "CRACKING".
2. NEVER WELD DIRECTLY TO THE TRUCK FRAME - FOLLOW THE TRUCK MANUFACTURER'S INSTRUCTIONS.
3. IF YOU ARE USING MOUNTS THAT UTILIZE BOLTS, LEAVE ALL OF THE BOLTS "FINGERTIGHT" UNTIL THE INSTALLATION HAS BEEN COMPLETED.
4. TO PROPERLY LOCATE THE FRONT MOUNTS, PLACE A STRAIGHT EDGE ALONG THE TOP OF THE FENDER AS SHOWN. (SEE "FRONT MOUNT LOCATION" BELOW FOR STEPS #4 THRU #6).
5. MEASURE STRAIGHT DOWN THE **MINIMUM** DISTANCE (**8-1/2"**) AND DRAW A LINE ALL THE WAY ACROSS THE FENDER USING A STRAIGHT EDGE AND A FELT TIP MARKER. REPEAT THIS PRECEDURE AND DRAW A LINE AT THE **MAXIMUM** DISTANCE (**13-1/2"**) ACROSS THE FENDER.
6. THE HOLES FOR THE FRONT TUBE OR SHAPED MOUNT MAY BE LOCATED AT ANY PLACE ALONG OR IN BETWEEN THESE TWO LINES.
7. UTILIZING BOARDS OR SOME OTHER MEANS ON TOP OF THE TIRES, PROP THE FENDER TO THE DESIRED POSITION WITH THE AIR BAGS DEFLATED TO ESTABLISH THE FINAL LOCATION OF THE FENDER MOUNTS.
8. MAKE SURE THE TOP OF THE FENDERS ARE LOW ENOUGH TO CLEAR THE TRAILER AND YOU HAVE THE PROPER CLEARANCE OVER THE TOP OF THE TIRES.
9. YOU ARE NOW READY TO LOCATE THE FRONT AND REAR MOUNTS. MAKE SURE YOU MAINTAIN THE 38-1/2" "MAXIMUM DISTANCE BETWEEN MOUNTS" AND MARK THE **EXACT** LOCATION OF THE MOUNTS.

MOUNT LOCATING DETAILS

WARNING!

TO PROTECT YOUR LIMITED WARRANTY, THE FRONT MOUNTS MUST BE LOCATED WITHIN THE **MIN. - MAX. RANGE** AND THE **MAXIMUM** DISTANCE BETWEEN THE FRONT AND REAR MOUNTS MUST NOT EXCEED 38-1/2" AS SHOWN BELOW. **DO NOT MOUNT MUD FLAPS ONTO THE FENDER.**

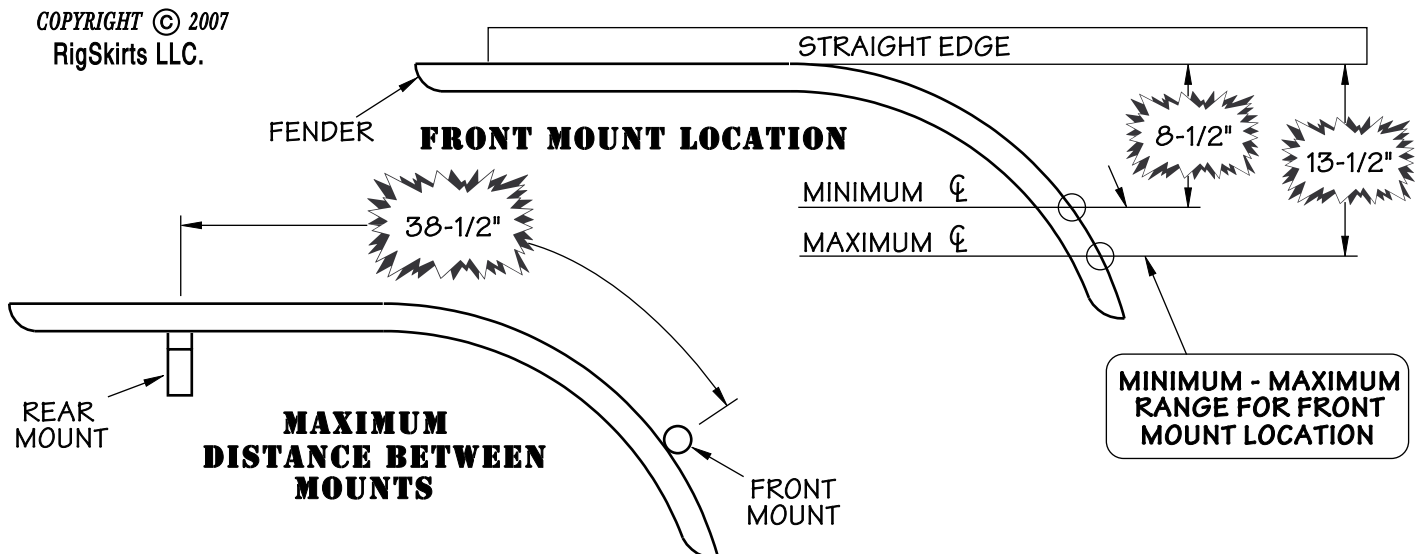

FENDER SIDE VIEWS