

SUPER MOUNT™ - SHAPED

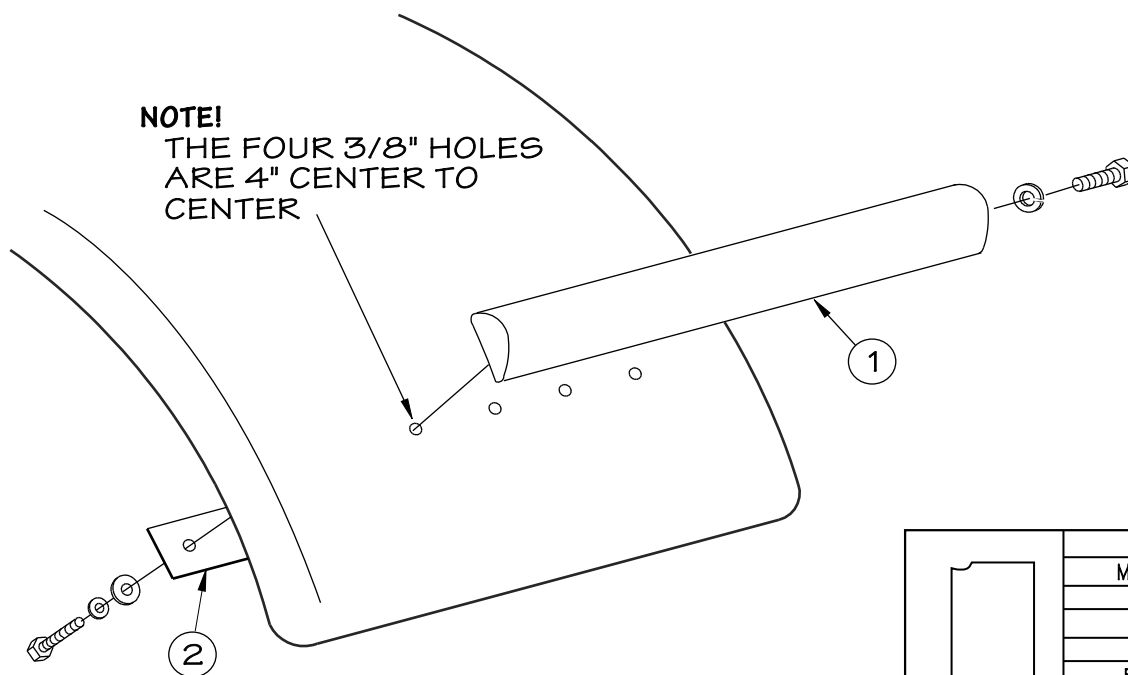
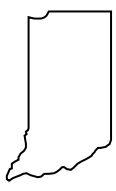

	MADE IN INDIANA
	(U.S.A.)
	BY "HOOSIERS"
	(AMERICANS)™

INSTRUCTIONS

1. MAKE SURE THE FENDER IS IN THE PROPER MOUNTING POSITION. (BOARDS OR SOME OTHER MEANS ON TOP OF THE TIRES WILL SERVE WELL FOR THIS OPERATION).
2. WITH THE FENDER IN THE PROPER POSITION, CAREFULLY MARK THE LOCATION OF THE HOLE TO BE DRILLED INTO THE TRUCK FRAME FOR THE 3/4" MOUNT BOLT. ALSO MARK AROUND THE OUTSIDE OF THE MOUNT (PART #1) IN ORDER TO DETERMINE THE LOCATION OF THE FOUR 3/8" HOLES TO BE DRILLED IN THE FENDER. (A FELT TIP MARKER WILL PERFORM WELL FOR THIS OPERATION).
3. REMOVE THE FENDERS FROM THE TRUCK. FINALIZE THE LOCATION OF THE HOLES IN THE FENDER. NOTE THAT THE PART CONTAINING THE THREADED INSERTS (ON THE UNDERSIDE OF THE MOUNT) WILL SLIDE FOR SIDE-TO-SIDE ADJUSTMENT AND EASE OF LOCATION.
4. DRILL THE HOLES IN THE FENDERS AND THE TRUCK FRAME.
5. BOLT THE MOUNT (PART #1) ONTO THE FENDER AND LEAVE THE BOLTS "FINGERTIGHT". MAKE SURE THE BOLTS PASS THROUGH THE BACKER PLATE (PART #2), THE FENDER AND ON INTO THE MOUNT EXCATLY AS SHOWN IN THE ILLUSTRATION ABOVE.
6. PLACE THE FENDER BACK INTO POSITION, BOLT THE MOUNT TO THE TRUCK FRAME AND TIGHTEN.
7. ADJUST THE FENDER FOR THE PROPER SIDE-TO-SIDE ALIGNMENT OVER THE TIRES. ALTERNATELY TIGHTEN EACH OF THE MOUNT BOLTS UNTIL THE LOCKWASHERS ARE COMPRESSED.
CAUTION: OVER TIGHTENING MAY RESULT IN DAMAGE TO THE FENDER.



BY

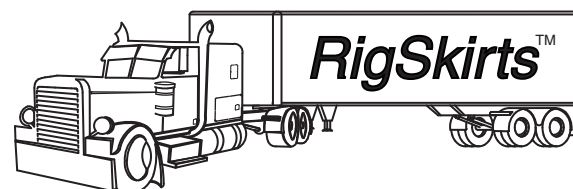

11/6/2007
408925INS

COPYRIGHT © 2007
RigSkirts LLC.
ALL RIGHTS RESERVED