

# SUPER MOUNT™ - TUBE

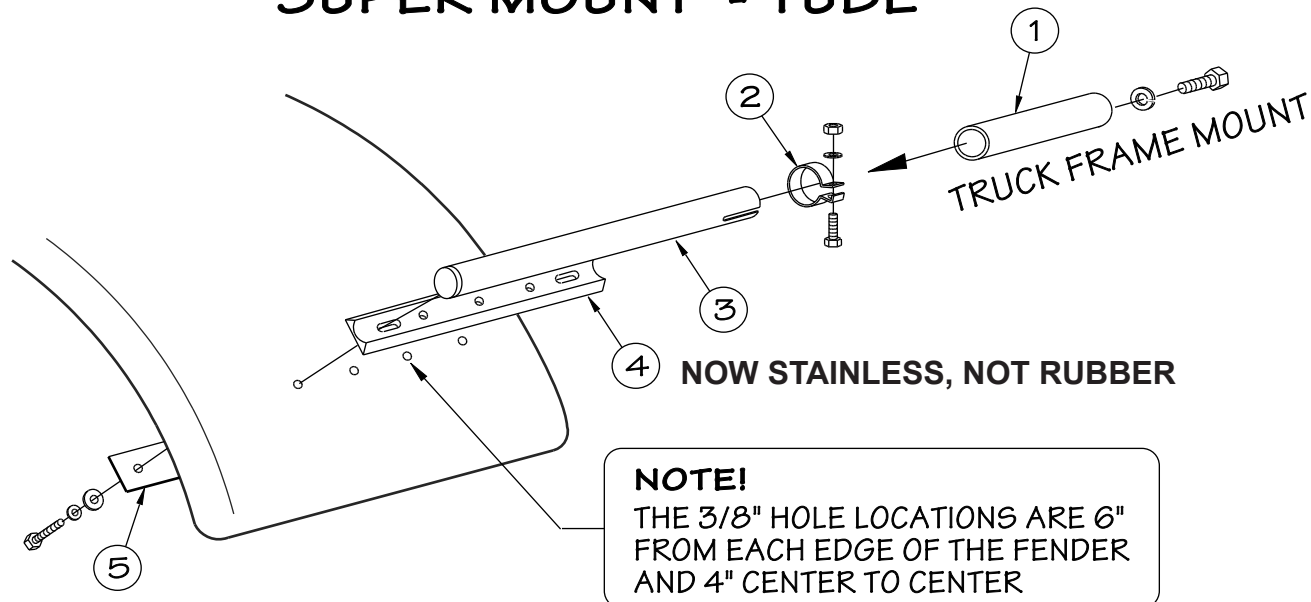

## INSTRUCTIONS

1. MAKE SURE THE FENDER IS IN THE PROPER MOUNTING POSITION. (BOARDS OR SOME OTHER MEANS ON TOP OF THE TIRES WILL SERVE WELL FOR THIS OPERATION).
2. INSERT THE TRUCK FRAME MOUNT (PART #1) INTO THE MOUNTING TUBES (PART #3). HOLD THIS ASSEMBLY IN THE DESIRED POSITION AND CAREFULLY MARK THE LOCATION OF THE HOLES TO BE DRILLED IN THE TRUCK FRAME AND THE FENDER. SEE NOTE ABOVE TO ASSIST IN LOCATING THE MOUNT TUBE HOLES IN THE FENDER.

**CAUTION: MAKE SURE THE STAINLESS ISOLATOR (PART #4) IS BETWEEN THE TUBE (PART #3) AND FENDER WHEN LOCATING ALL HOLES.**

3. REMOVE THE FENDERS FROM THE TRUCK. DRILL THE HOLES IN THE FENDERS AND THE TRUCK FRAME.
4. BOLT THE TRUCK FRAME MOUNTS (PART #1) ONTO THE TRUCK FRAME AND TIGHTEN.
5. ATTACH THE MOUNTING TUBES (PART #3) TO THE FENDERS MAKING SURE THAT THE BOLTS PASS THROUGH THE BACKER PLATE (PART #5), FENDER, RUBBER ISOLATOR (PART #4) AND INTO THE TUBE. AFTER YOU HAVE THEM ASSEMBLED TO A "FINGERTIGHT" CONDITION, ALTERNATELY TIGHTEN EACH BOLT UNTIL THE LOCK WASHERS ARE COMPRESSED.  
**CAUTION: OVER TIGHTENING MAY RESULT IN DAMAGE TO THE FENDER.**
6. PLACE THE TUBE CLAMP (PART #2) OVER THE MOUNTING TUBE AND SLIDE THIS COMPLETED ASSEMBLY ONTO THE TRUCK FRAME MOUNT (PART #1).
7. CHECK FENDER FOR PROPER SIDE-TO-SIDE ALIGNMENT AND TIGHTEN ALL BOLTS.

|  |                 |
|--|-----------------|
|  | MADE IN INDIANA |
|  | (U.S.A.)        |
|  | BY "HOOSIERS"   |
|  | (AMERICANS)™    |
|  |                 |



BY



11/6/2007  
408934INS

COPYRIGHT © 2007  
RigSkirts LLC.  
ALL RIGHTS RESERVED