

SINGLE AXLE FENDER ASSEMBLY

19" HOT SHOT

NOTE!

MOUNT TUBE HOLES ARE NOT PROVIDED IN THE FENDER DUE TO THE VARIATIONS IN TRUCK MODEL APPLICATIONS.

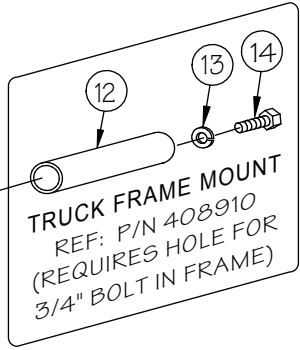
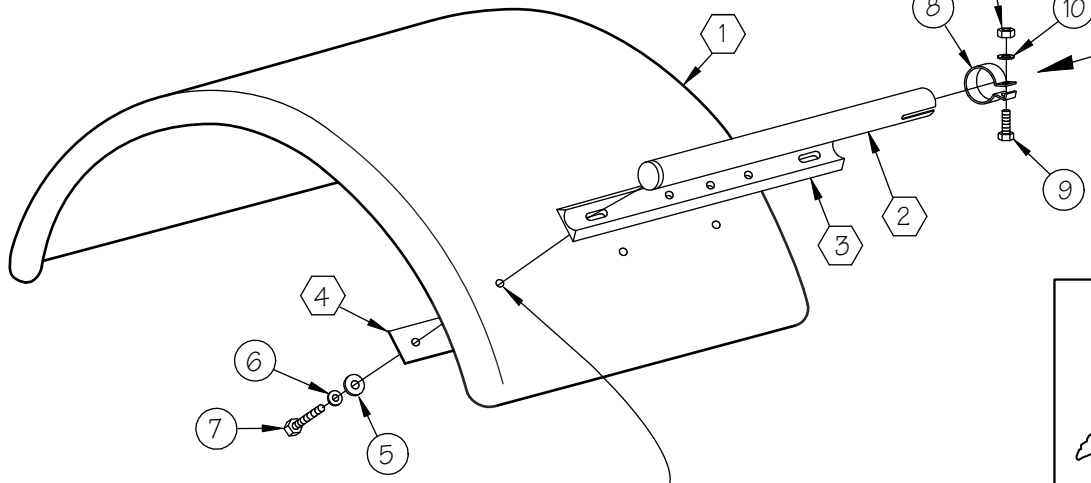

	MADE IN INDIANA
	(U.S.A.)
	BY "HOOSIERS"
	(AMERICANS)™

(3/8" HOLE LOCATION IS 4" FROM EDGE OF FENDER AND 5-1/2" CENTER TO CENTER)

PARTS LIST

NO.	DESCRIPTION	QUANTITY	NO.	DESCRIPTION	QUANTITY	NO.	DESCRIPTION	QUANTITY
1	FENDER	2	2	MOUNTING TUBE	4	3	STAINLESS SHIM	4
4	BACK UP PLATE	4	5	FLAT WASHER 5/16"	12	6	LOCKWASHER 5/16"	12
7	HEX BOLT 5/16" x 1-1/2"	12	8	TUBE CLAMP	4	9	HEX BOLT 3/8" x 1-1/4"	4
10	LOCKWASHER 3/8"	4	11	HEX NUT 3/8"	4	12	TRUCK FRAME MOUNT	4
13	LOCKWASHER 3/4"	4	14	HEX BOLT 3/4" x 3/4"	4			

QUANTITIES SHOWN ARE FOR ONE PAIR

INSTRUCTIONS

- UNPACK THE BOXES, CHECK THE PIECES FOR COUNT AND MAKE A "DRY RUN" COMPLETELY THROUGH THE INSTRUCTIONS TO FAMILIARIZE YOURSELF WITH THE INDIVIDUAL PIECES AND THE WAY THEY BOLT TOGETHER.
- UTILIZING BOARDS OR SOME OTHER MEANS, PROP THE FENDER ON TOP OF THE TIRES TO THE DESIRED POSITION AND CAREFULLY MARK THE LOCATION OF THE MOUNT TUBES (OR OPTIONAL SHAPED MOUNTS) AND THE LOCATION OF THE HOLES TO BE DRILLED INTO THE FRAME. MAKE SURE THE STAINLESS SHIM (PART #3) IS BETWEEN THE TUBE AND THE FENDER WHEN LOCATING THESE HOLES.
- LEAVE AMPLE ROOM BETWEEN THE FENDER AND TIRE TO PREVENT "BOTTOMING OUT". SEE NOTE ABOVE TO ASSIST IN LOCATING THE HOLES TO BE DRILLED IN THE FENDER. REMOVE THE FENDERS PRIOR TO DRILLING THESE HOLES.
- BOLT THE TRUCK FRAME MOUNTS (PART #12) TO THE TRUCK FRAME AND TIGHTEN. **NOTE!** IT IS A GOOD IDEA TO APPLY A SMALL AMOUNT OF "LOCTITE" TO ALL OF THE BOLTS AS YOU TIGHTEN THEM.
- ATTACH MOUNTING TUBES (PART #2) TO THE FENDERS. AFTER YOU HAVE THEM ASSEMBLED TO A "FINGERTIGHT" CONDITION, ALTERNATELY TIGHTEN EACH BOLT UNTIL THE LOCKWASHERS ARE COMPRESSED. **CAUTION: OVER TIGHTENING MAY RESULT IN DAMAGE TO THE FENDER.**
- SLIDE THE TUBE CLAMPS (PART #8) OVER THE MOUNTING TUBES (PART #2). SLIDE THE COMPLETELY ASSEMBLED FENDER OVER THE TRUCK FRAME MOUNTS (PART #12) AND TIGHTEN THE CLAMPS. A SLIGHT AMOUNT OF GREASE ON THE TRUCK FRAME MOUNTS WILL ASSIST IN THIS OPERATION.
- USE WINDEX AND A SOFT COTTON CLOTH TO CLEAN THE FENDERS AFTER THE INSTALLATION IS COMPLETED. **CAUTION: NEVER USE A WAX THAT CONTAINS AN ABRASIVE AS IT WILL DAMAGE THE FINISH.**
- AFTER THIS INSTALLATION HAS BEEN COMPLETED, CHECK THE FENDER BOLTS PERIODICALLY TO INSURE THAT THEY HAVE REMAINED TIGHT DURING NORMAL OPERATION OF THE TRUCK.



BY



COPYRIGHT © 2007
RigSkirts LLC.
ALL RIGHTS RESERVED