

# QUAL-COM MOUNT

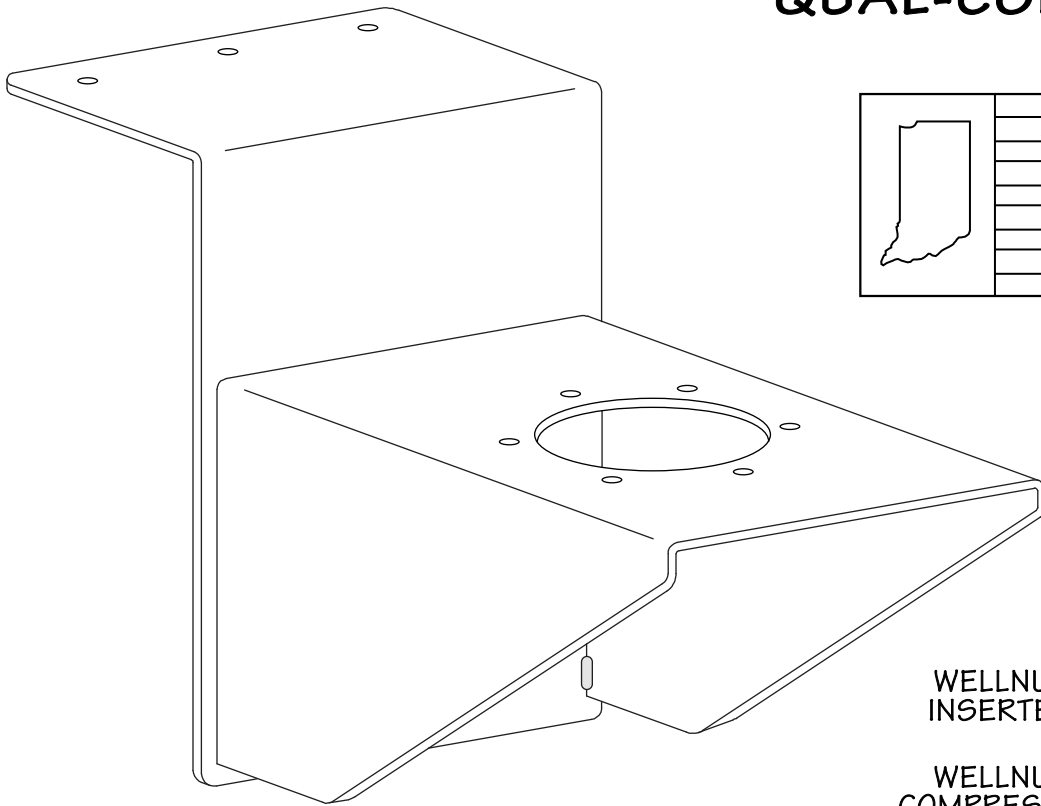

	MADE IN INDIANA
	(U.S.A.)
	BY "HOOSIERS"
	(AMERICANS)™

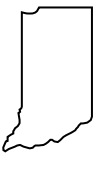
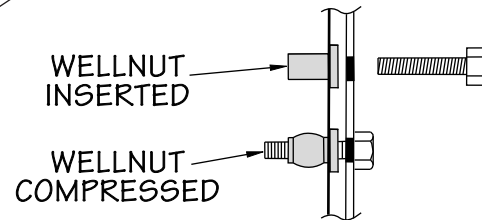

ILLUSTRATION - WELLNUTS

## INSTRUCTIONS

1. CHOOSE THE BEST LOCATION FOR THE UNIT BEARING IN MIND BOTH RECEPTION AND EASE OF INSTALLATION.
2. HOLD THE MOUNTING BASE IN THE PROPER POSITION AND MARK THE HOLES TO BE DRILLED WITH A FELT TOP MARKER.
3. USE A CENTER PUNCH TO PREVENT "DRIFTING" AND DRILL A SMALL 1/8" DIAMETER LEAD-IN HOLE AT ALL LOCATIONS. THEN DRILL THESE MOUNT HOLES ON OUT TO 1/2" DIAMETER.

**NOTE!** IT IS BEST TO USE A DEPTH-STOP OR WRAP A PIECE OF TAPE AROUND THE DRILL BIT TO AVOID PENETRATING DEEPER THAN NECESSARY AND CAUSING DAMAGE TO THE INTERIOR.

4. INSERT THE WELLNUTS INTO THE HOLES AND PRESS FIRMLY INTO PLACE AS SHOWN IN THE **ILLUSTRATION - WELLNUTS** (THESE ARE THE FASTENERS WITH THE THREADED INSERT INSIDE). **NOTE!** DO **NOT** USE CAULKING OR ANY SIMILAR PRODUCTS AS THE WELLNUTS ARE SELF-SEALING.
5. PLACE THE MOUNTING BASE BACK INTO POSITION, INSERT THE BOLTS AND TIGHTEN. STOP THE TIGHTENING MOVEMENT AS SOON AS YOU FEEL THE BOLTS "BOTTOM OUT" TO PREVENT OVER TIGHTENING.

COPYRIGHT © 2007  
RigSkirts LLC.  
ALL RIGHTS RESERVED



BY

