

KENWORTH STANDARD AND EXTENDED VISORS

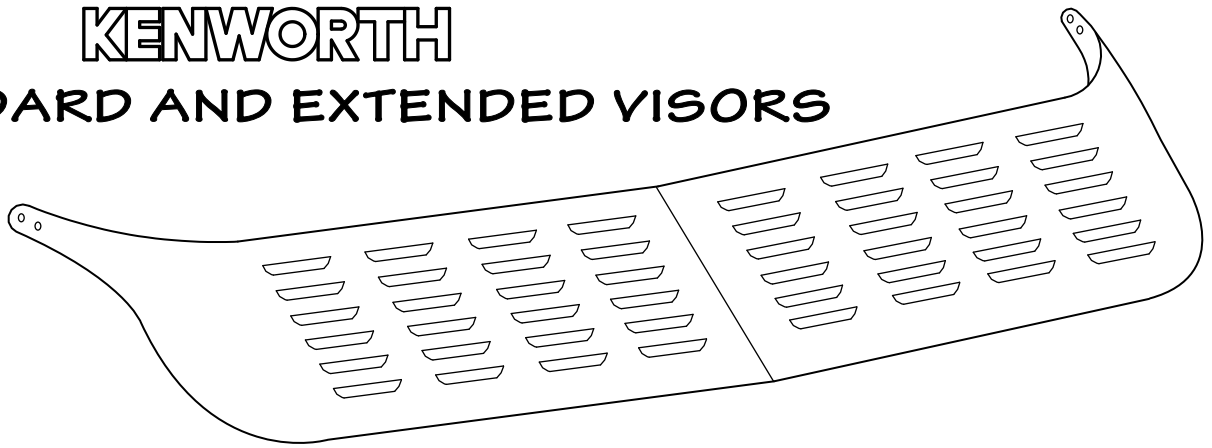

BY

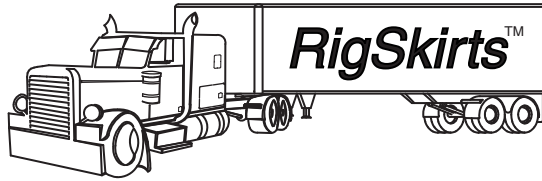

PARTS REQUIRED FOR THIS INSTALLATION



MOUNT BRACKETS - 3 REQUIRED

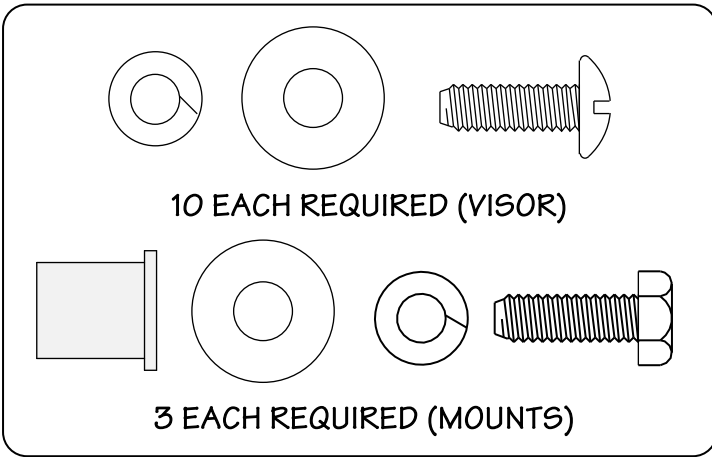

10 EACH REQUIRED (VISOR)

3 EACH REQUIRED (MOUNTS)

VISOR SECTIONS

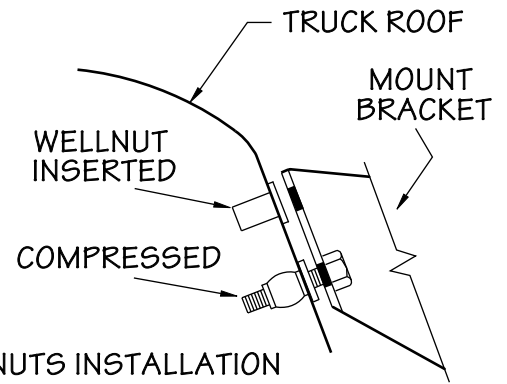
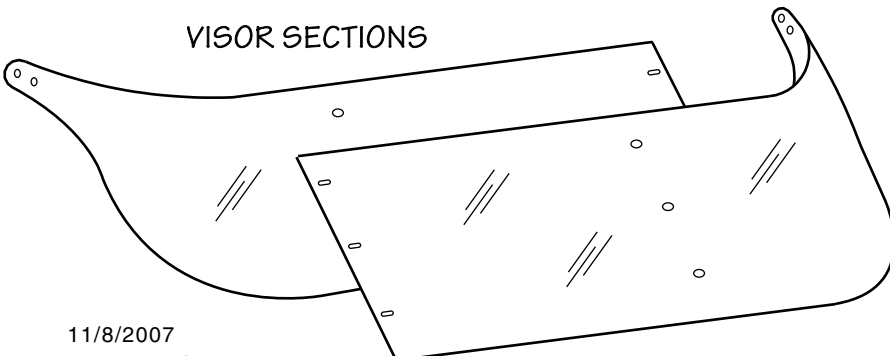

WELLNUTS INSTALLATION

ILLUSTRATION #1

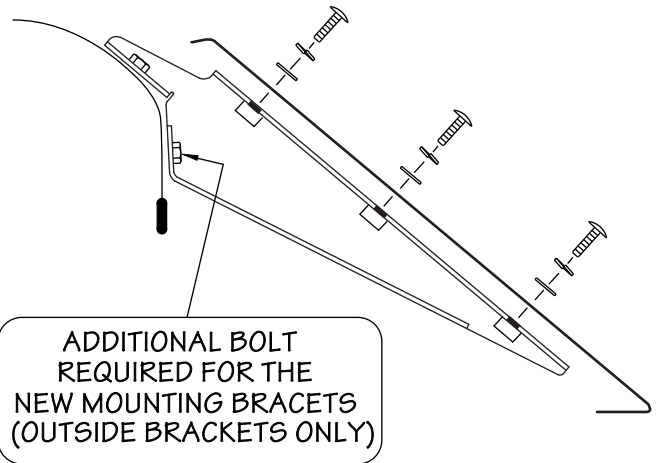

ILLUSTRATION #2

	MADE IN INDIANA
	(U.S.A.)
	BY "HOOSIERS"
	(AMERICANS)™

KENWORTH STANDARD AND EXTENDED VISORS

INSTRUCTIONS

1. UNPACK THE CARTON AND DETERMINE THAT ALL PIECES REQUIRED FOR THIS INSTALLATION ARE IN THE BOX. (SEE REVERSE SIDE). PAY PARTICULAR ATTENTION TO THE BOLTS AS THIS INSTALLATION CANNOT BE COMPLETED WITHOUT THE PROPER AMOUNT AND TYPE OF BOLTS AND FASTENERS. YOU WILL ALSO NEED A SMALL AMOUNT OF WINDSHIELD ADHESIVE (SEE STEP #8)
2. REMOVE THE EXISTING SUN VISOR FROM THE TRUCK. PUT THE FOUR BOLTS FROM THE SIDES OF THE VISOR TEMPORARILY BACK IN THEIR RESPECTIVE POSITIONS AS WE WILL BE RE-USING THEM.
3. REMOVE THE EXISTING MOUNTING BRACKETS FROM THE TRUCK AND THROW THEM AWAY AS WE WILL NOT BE USING THEM. PUT THE FOUR BOLTS IN A CONTAINER AS WE WILL BE RE-USING THEM TO MOUNT THE NEW BRACKETS.
4. THE NEXT FIVE STEPS (#5 THROUGH #9) ARE THE MOST IMPORTANT AND REQUIRE THE UTMOST IN CARE AND CAUTION AS WE WILL BE ADDING AN ADDITIONAL BOLT AT THE BOTTOM OF THE TWO **OUTSIDE** BRACKETS.
5. INSTALL THE CENTER MOUNTING BRACKET AND TIGHTEN. MOUNT THE TWO OUTSIDE BRACKETS BY INSTALLING A BOLT THROUGH THE **TOP** HOLE OF EACH BRACKET AND LEAVE THE BOLTS "FINGERTIGHT". (SEE ILLUSTRATION #2)
6. MAKE SURE THE SIDES OF THE TWO OUTSIDE BRACKETS ARE PLUMB AND MARK THE LOCATION OF THE TWO HOLES TO BE DRILLED INTO THE TRUCK ROOF (THE **BOTTOM** HOLE IN EACH BRACKET). REMOVE THE TWO OUTSIDE BRACKETS.
7. USE A CENTER PUNCH TO PREVENT "DRIFTING" AND DRILL A SMALL 1/8" DIAMETER LEAD-IN HOLE AT BOTH LOCATIONS. DRILL THE TWO MOUNT HOLES ON OUT TO 1/2" DIAMETER.
NOTE! IT IS BEST TO USE A DEPTH-STOP OR WRAP A PIECE OF TAPE AROUND THE DRILL BIT TO AVOID PENETRATING DEEPER THAN NECESSARY AND CAUSING DAMAGE TO THE HEADLINER.
8. TAKE A SMALL FINE-TOOTH FILE AND DEBURR AROUND AND INSIDE OF THE HOLES. APPLY WINDSHIELD ADHESIVE AROUND THE OUTSIDE AND UNDER THE LIP OF THE WELLNUTS, THEN INSERT THEM INTO THE HOLES AND PRESS FIRMLY INTO PLACE AS SHOWN IN ILLUSTRATION #1. (THESE ARE THE FASTENERS WITH THE THREADED INSERTS INSIDE).
9. INSTALL THE TWO OUTSIDE MOUNTING BRACKETS IN PLACE AS SHOWN IN ILLUSTRATION #2. BE VERY CAREFUL NOT TO OVERTIGHTEN THE WELLNUTS. STOP THE TIGHTENING MOVEMENT AS SOON AS YOU FEEL THE BOLT BOTTOM OUT.
10. PEEL THE P.V.C. PROTECTIVE COATING FROM THE RIGHT (PASSENGER) SIDE VISOR. REMOVE THE TWO BOLTS THAT WE TEMPORARILY LEFT IN PLACE (SEE STEP #2) AND LOOSELY BOLT THE END OF THE VISOR TO THE TRUCK. ALSO PLACE ONE OF THE NEW BOLTS THROUGH THE VISOR AND INTO THE OUTSIDE BRACKET TO TEMPORARILY HOLD IT IN POSITION. REPEAT THIS PROCESS TO INSTALL THE VISOR ON THE OTHER (DRIVERS) SIDE.
11. INSTALL THE THREE BOLTS WHERE THE TWO VISORS JOIN AT THE MIDDLE BRACKET AND LEAVE THEM IN A "FINGERTIGHT" CONDITION.
12. INSTALL THE REMAINING BOLTS IN THE TWO SIDE BRACKETS.
13. CHECK FOR PROPER ALIGNMENT AND TIGHTEN ALL BOLTS.
14. USE WINDEX AND A SOFT COTTON CLOTH TO CLEAN THE VISOR AFTER THE INSTALLATION IS COMPLETED. NEVER USE AN ABRASIVE COMPOUND TO CLEAN THE STAINLESS AS IT WILL DAMAGE THE FINISH.