

FREIGHTLINER CABOVER & FLD DROPPED VISOR

COPYRIGHT © 2007
RigSkirts LLC.
ALL RIGHTS RESERVED

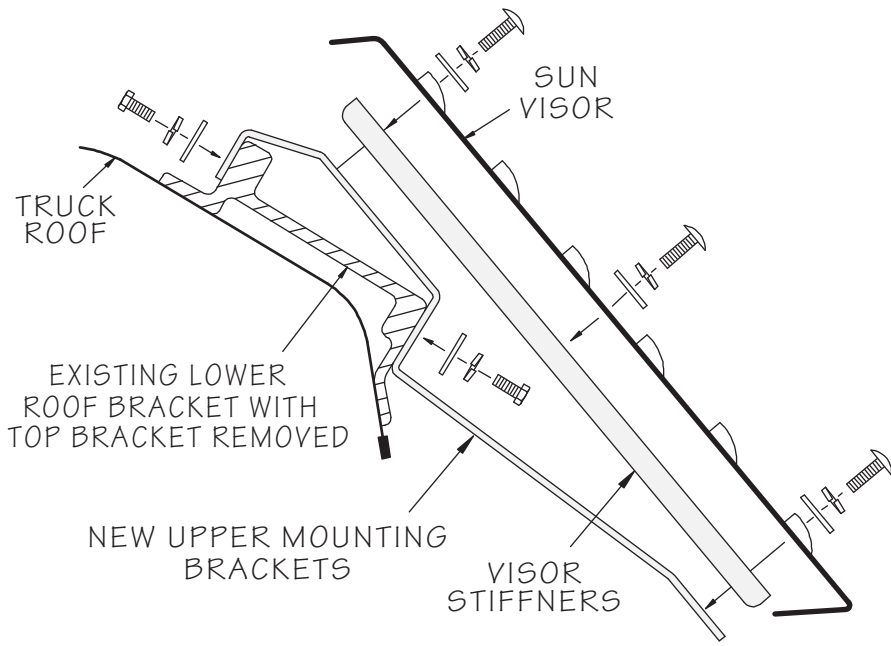

ILLUSTRATION

PARTS REQUIRED
FOR THIS
INSTALLATION

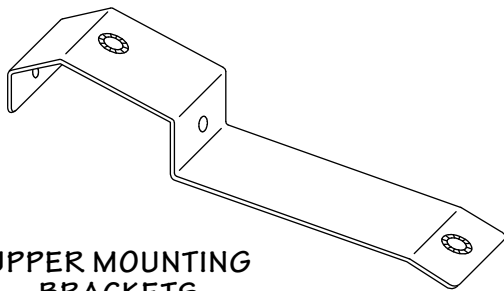

UPPER MOUNTING
BRACKETS
4 REQUIRED

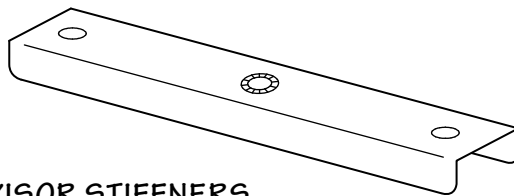

VISOR STIFFENERS
4 REQUIRED

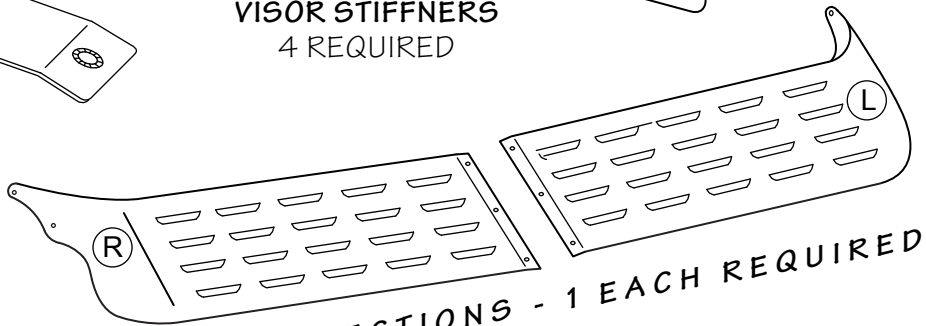

VISOR SECTIONS - 1 EACH REQUIRED



BY

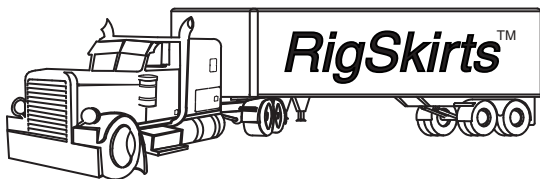

11/12/2007
61050INS

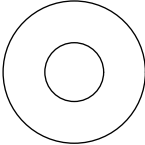
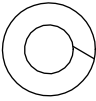
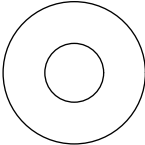
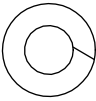
B O L T K I T	3 EACH REQUIRED (VISOR JOINT)		
	15 EACH REQUIRED (VISOR)		
	8 EACH REQUIRED (MOUNTS)		

FREIGHTLINER CABOVER & FLD DROPPED VISOR

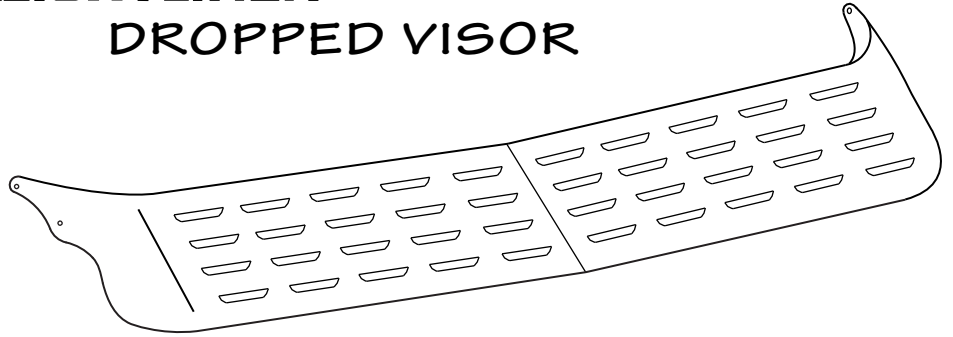
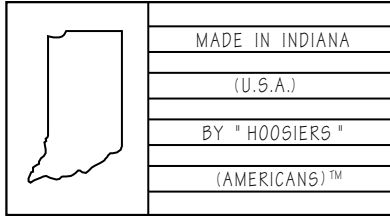

INSTRUCTIONS

1. UNPACK THE CARTON AND DETERMINE THAT ALL PIECES REQUIRED FOR THIS INSTALLATION ARE IN THE BOX. (SEE REVERSE SIDE). PAY PARTICULAR ATTENTION TO THE BOLTS AS THIS INSTALLATION CANNOT BE COMPLETED WITHOUT THE PROPER AMOUNT AND TYPE OF BOLTS. **NOTE! YOU MUST USE ALL OF THE PARTS SHOWN ON THE REVERSE SIDE OF THIS PAGE OR YOUR WARRANTY BECOMES NULL AND VOID.**
2. REMOVE THE EXISTING VISOR FROM THE TRUCK AND PUT THE FOUR BOLTS FROM THE ENDS OF THE VISOR BACK INTO THEIR RESPECTIVE HOLES AS WE WILL USE THEM TO MOUNT THE NEW VISOR.
3. APPLY **P B BLASTER** OR **LIQUID WRENCH** ON THE BOLTS THAT JOIN THE UPPER AND LOWER VISOR MOUNTING BRACKETS ALLOWING ENOUGH TIME TO SOAK-IN. **CAUTION** GINGERLY APPLY PRESSURE TO YOUR WRENCH AS YOU PREPARE TO REMOVE THESE BOLTS. THIS WILL LESSEN THE RISK OF BREAKING THEM OFF.
4. REMOVE THE **UPPER** PART OF THE EXISTING VISOR MOUNTING BRACKETS AND THROW THEM AWAY AS WE WILL NOT BE USING THEM. (SEE ILLUSTRATION ON REVERSE SIDE)
5. INSTALL THE NEW UPPER MOUNTING BRACKETS AS SHOWN IN THE ILLUSTRATION UTILIZING THE NEW BOLTS SUPPLIED IN THIS KIT AND TIGHTEN.
6. PEEL THE P.V.C. PROTECTIVE COATING FROM THE VISOR SECTIONS AND BOLT THE FOUR VISOR STIFFNERS ONTO THE BACKSIDE OF THE VISOR SECTIONS WITH ONLY **ONE** BOLT IN THE **CENTER** HOLE OF EACH STIFFNER. LEAVE THESE AND ALL THE REST OF THE BOLTS IN A "FINGERTIGHT" CONDITION UNTIL THIS VISOR INSTALLATION HAS BEEN COMPLETED.
7. BOLT THE RIGHT VISOR SECTION (PASSENGER SIDE) ONTO THE TRUCK. THIS IS BEST ACCOMPLISHED BY INSTALLING THE TWO BOLTS AT THE END OF THE VISOR FIRST AND THEN INSTALLING THE FOUR REMAINING BOLTS INTO THE MOUNTING BRACKETS. MAKE SURE THE VISOR STIFFNERS ARE ALIGNED PROPERLY TO PERMIT THE BOLTS TO PASS THROUGH THE VISOR **AND** THE STIFFNERS.
8. REPEAT STEP #6 AND INSTALL THE LEFT VISOR SECTION (DRIVERS SIDE) MAKING SURE THIS SIDE IS ON TOP OF THE OTHER VISOR SECTION AT THE MID-JOINT.
9. INSTALL THE THREE BOLTS, NUTS, WASHERS AND LOCKWASHERS AT THE VISOR MID-JOINT.
10. CHECK EVERYTHING FOR PROPER ALIGNMENT AND TIGHTEN THE BOLTS. **NOTE!** IT IS A GOOD IDEA TO APPLY A SMALL AMOUNT OF LOCTITE TO ALL OF THE BOLTS WHEN YOU TIGHTEN THEM.
11. USE WINDEX AND A SOFT COTTON CLOTH TO CLEAN THE VISOR AFTER INSTALLATION. NEVER USE AN ABRASIVE COMPOUND ON THE STAINLESS AS IT WILL DAMAGE THE FINISH.
12. AFTER THIS INSTALLATION HAS BEEN COMPLETED, CHECK THE VISOR BOLTS PERIODICALLY TO INSURE THAT THEY HAVE REMAINED TIGHT DURING NORMAL OPERATION OF THE TRUCK.