

"K100E" KENWORTH CABOVER DROPPED VISOR

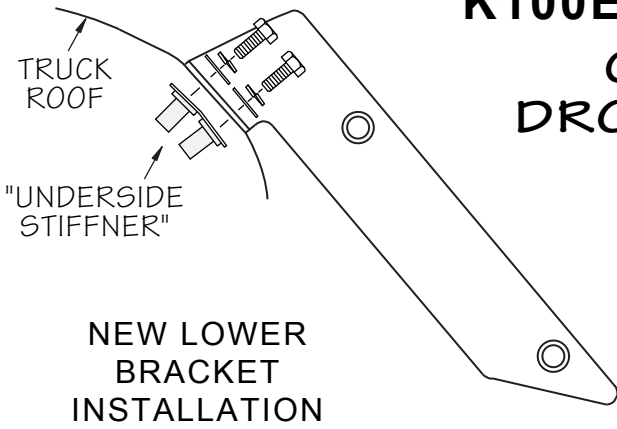

**MOUNT
BRACKET
ORIENTATION**

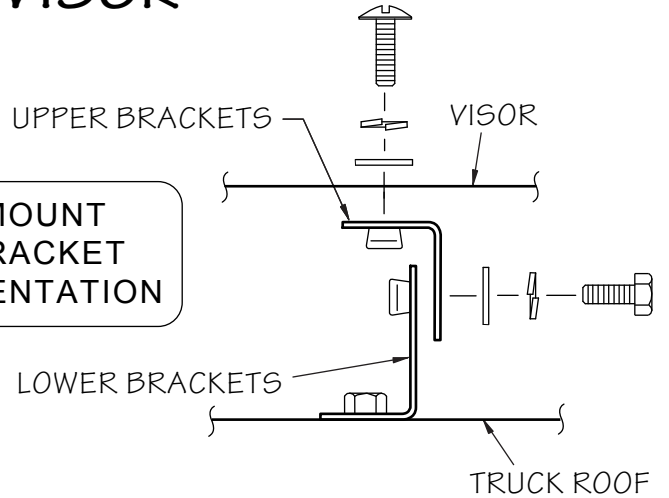

**TOP VIEW
(RIGHT SIDE SHOWN)**

PARTS REQUIRED FOR THIS INSTALLATION

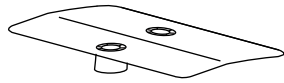

UNDERSIDE STIFFNERS
6 EACH REQUIRED

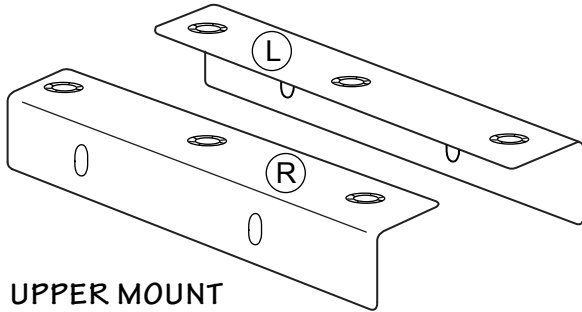

**UPPER MOUNT
BRACKETS**
3 EACH REQUIRED

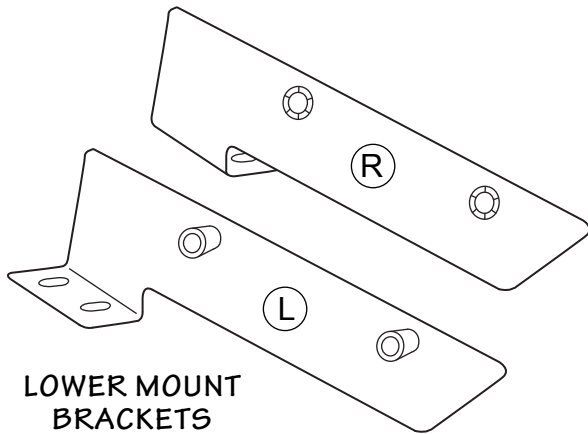

**LOWER MOUNT
BRACKETS**
3 EACH REQUIRED
(RIGHT & LEFT)

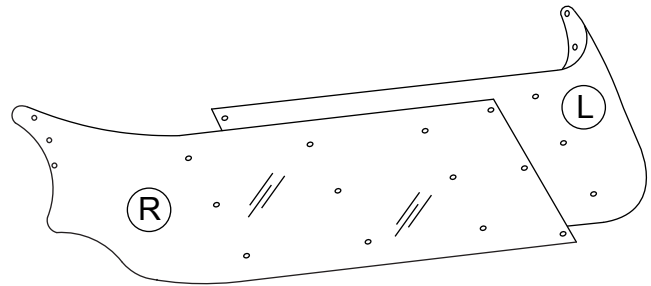

VISOR SECTIONS
1 EACH REQUIRED

B O L T			
	21 EACH REQUIRED (VISOR)		
K I T	12 EACH REQUIRED (MOUNTS)		
		4 EACH REQUIRED	

"K100E" KENWORTH CABOVER DROPPED VISOR

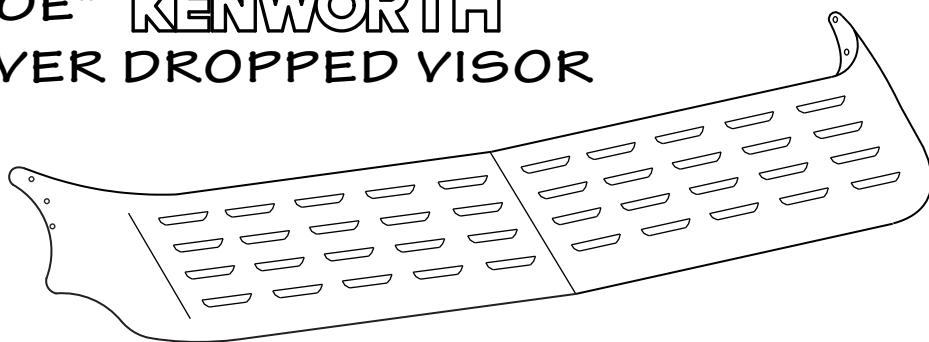
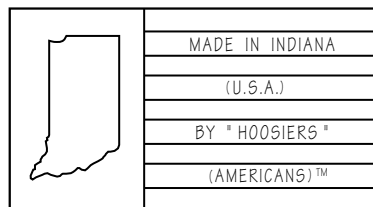

INSTRUCTIONS

- UNPACK THE CARTON AND DETERMINE THAT YOU HAVE RECEIVED ALL OF THE PARTS REQUIRED FOR THIS INSTALLATION. **NOTE! YOU MUST USE ALL OF THE PARTS SHOWN ON THE REVERSE SIDE OF THIS PAGE OR YOUR WARRANTY BECOMES NULL AND VOID.**
- REMOVE THE EXISTING VISOR AND BRACKETS FROM THE TRUCK ROOF AND PUT THE SIX BOLTS FROM THE ENDS OF THE VISOR BACK INTO THEIR RESPECTIVE POSITIONS AS WE WILL USE THEM TO MOUNT THE NEW VISOR.
- LEAVE THE P.V.C. PROTECTIVE COATING ON THE VISOR SECTIONS AND BOLT THE ENTIRE UNIT TOGETHER WITH ALL SIX OF THE NEW MOUNTING BRACKETS. TIGHTEN THE BOLTS ONLY SLIGHTLY MORE THAN "FINGER-TIGHT".
- PLACE THE COMPLETELY ASSEMBLED VISOR UNIT INTO THE PROPER POSITION ON THE TRUCK ROOF, PLACE THE SIX END BOLTS INTO POSITION AND TIGHTEN. THIS WILL HELP HOLD THE UNIT IN PLACE WHILE PERFORMING THE NEXT STEP.
- MARK THE LOCATION OF ALL THE HOLES TO BE DRILLED INTO THE ROOF OF THE TRUCK FOR THE NEW MOUNTING BRACKETS AND THEN REMOVE THE VISOR. **NOTE!** IT MAY BE NECESSARY TO PULL UP ON THE CENTER OF THE VISOR WHILE PREPARING TO MARK THE HOLE LOCATIONS.
- USE A CENTER PUNCH TO PREVENT "DRIFTING" AND DRILL A SMALL 1/8" DIAMETER LEAD-IN HOLE AT ALL LOCATIONS. DRILL THE EIGHT MOUNT HOLES ON OUT TO 1/2" (.500) DIAMETER. **NOTE!** IT IS BEST TO USE A DEPTH-STOP OR WRAP A PIECE OF TAPE AROUND THE DRILL BIT TO AVOID PENETRATING DEEPER THAN NECESSARY AND CAUSING DAMAGE TO THE HEADLINER.
- TAKE A SMALL FINE-TOOTH FILE AND DEBURR AROUND AND INSIDE OF THE HOLES.
- DISASSEMBLE THE VISOR AND INSTALL THE SIX NEW MOUNTING BRACKETS, ALONG WITH THE UNDERSIDE STIFFENERS, IN PLACE AS SHOWN IN THE ILLUSTRATION. BE VERY CAREFUL NOT TO OVERTIGHTEN THESE BOLTS. STOP THE TIGHTENING MOVEMENT AS SOON AS YOU FEEL THE BOLT BOTTOM OUT.
- PEEL THE P.V.C. PROTECTIVE COATING FROM THE RIGHT (PASSENGER) SIDE VISOR SECTION. PLACE THE VISOR SECTION IN POSITION. INSTALL THE THREE BOLTS IN THE END AND THEN INSTALL THE BOLTS THROUGH THE VISOR AND ON INTO THE ROOF MOUNTING BRACKETS. LEAVE ALL BOLTS "FINGERTIGHT" UNTIL THIS INSTALLATION HAS BEEN COMPLETED.
- REPEAT STEP #8 AND INSTALL THE LEFT (DRIVERS) SIDE VISOR SECTION.
- INSTALL THE BOLTS THROUGH BOTH SECTIONS WHERE THE TWO VISORS JOIN. CHECK FOR PROPER ALIGNMENT AND TIGHTEN ALL BOLTS. **NOTE!** IT IS A GOOD IDEA TO APPLY A SMALL AMOUNT OF LOCTITE TO ALL OF THE BOLTS WHEN YOU TIGHTEN THEM.
- USE WINDEX AND A SOFT COTTON CLOTH TO CLEAN THE VISOR AFTER INSTALLATION. NEVER USE AN ABRASIVE COMPOUND ON THE STAINLESS AS IT WILL DAMAGE THE FINISH.
- AFTER THIS INSTALLATION HAS BEEN COMPLETED, CHECK THE VISOR BOLTS PERIODICALLY TO INSURE THAT THEY HAVE REMAINED TIGHT DURING NORMAL OPERATION OF THE TRUCK.



BY

