

SLEEPER REAR WINDOW VISOR

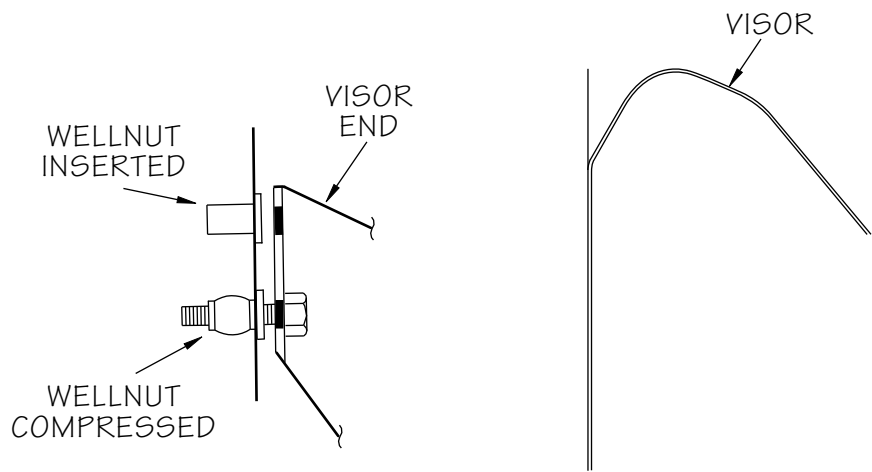
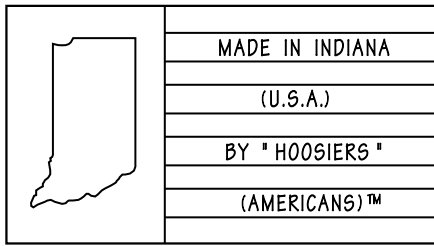

WELLNUTS INSTALLATION

INSTRUCTIONS

1. MAKE SURE THE VISOR IS ALIGNED PROPERLY AND MARK THE LOCATION OF THE HOLES TO BE DRILLED INTO THE TRUCK.
2. USE A CENTER PUNCH TO PREVENT "DRIFTING" AND DRILL A SMALL 1/8" DIAMETER LEAD-IN HOLE AT ALL HOLE LOCATIONS. DRILL THE MOUNT HOLES ON OUT TO 1/2" DIAMETER. **NOTE!** IT IS BEST TO USE A DEPTH-STOP OR WRAP A PIECE OF TAPE AROUND THE DRILL BIT TO AVOID PENETRATING DEEPER THAN NECESSARY AND CAUSING DAMAGE TO THE INTERIOR.
3. TAKE A SMALL FINE-TOOTH FILE AND DEBURR AROUND AND INSIDE OF THE HOLES. THEN INSERT THEM INTO THE HOLES AND PRESS FIRMLY INTO PLACE AS SHOWN IN ILLUSTRATION #1. (THESE ARE THE FASTENERS WITH THE THREADED INSERTS INSIDE).
4. BOLT THE VISOR IN PLACE BEING CAREFUL NOT TO OVERTIGHTEN THE WELLNUTGS. STOP THE TIGHTENING MOVEMENT AS SOON AS YOU FEEL THE BOLT BOTTOM OUT.



BY

